

True touch control HD - Touch screen Display

Superior cooking results FAST!

- 2000W impingement enhances browning. Easily adjustable 0-100% fan speed
- 95° - 270°C (200° - 520°F) convection temperature range
- 3000W Infra-red radiant enhances toasting, browning, and crisping
- 2000 - 2200W dual side antenna feed microwave system heats quickly reduces cooking time

The MXP522ITLT cooks up to 15 times faster than conventional cooking so you can cook to order, minimise waste and reduce customer waiting times. The "One-touch" cooking provides consistent cooking, every time. In-built catalytic converter filters grease and odour from the air.



### STANDARD FEATURES

- USB, WIFI, ethernet for menu management
- Two removable / cleanable air filters
- Non stick liners installed for easier cleaning
- Enamelled element cover / tray

### OPTIONAL FEATURES

- Oven paddle
- Pizza Stone
- Non-stick basket
- Leg kit (102mm height)
- Panini Press

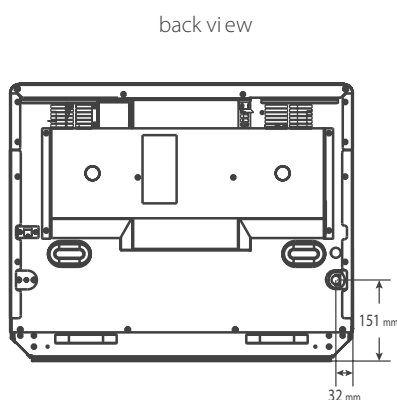
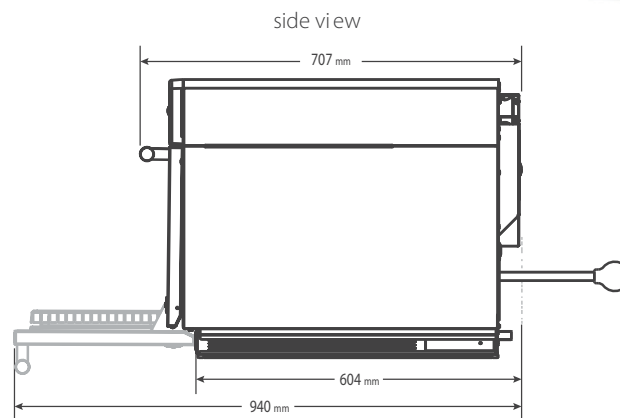
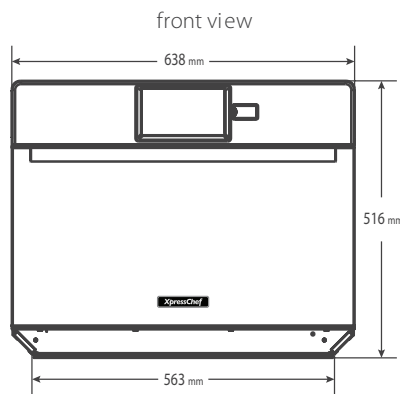

### DIMENSIONS

External dimensions: 638W x 699D x 518H mm

Internal cavity: 406W x 381D x 254H mm

### POWER SUPPLY

415V 50Hz 20A three phase, plugged

### TECHNICAL DATA

Power output:	5800W Total 2000W Convection, 2200W Microwave, 3000W Infra-red radiant
Internal cavity volume:	39 litres
External cabinet finish:	Stainless steel
Internal cavity finish:	Stainless steel & Teflon liner (replaceable)
Memory programs:	360
Power levels:	11
Product weight:	68kg
Shipping weight:	79kg
Magnetrons:	2

SPECIFICATIONS ARE SUBJECT TO CHANGE WITHOUT NOTICE.



MA005A MenuMaster MXP5223TLT Specification Sheet Issue 004 | Issue Date: 01/02/2023